

DUAL DOUBLE ACTING PNEUMATIC ACTUATOR



DUAL's Double Acting Pneumatic Actuators are manufactured with lightweight composite tubing, which is fibreglass - reinforced epoxy. It has an impact strength of 4012OD ft-lbs, which makes the actuator much more dent-resistant than aluminium or brass. The composite tubing is protected by a stainless steel cover to add extra protection against abuse in the plant. Both the piston rod and seal are protected by a wiper ring which cleans the piston rod before it is passed through the lip seal contributing to extended actuator life. The actuator is self lubricating and this feature greatly increases the life of the O-ring.

FEATURES

- Simple design.
- Urethane rod wiper.
- Corrosion proof and robust construction.
- Manufactured to fit all types of valves.
- Stroke adjustment feature.
- Smooth operation.
- Easily maintained.
- Double O-Ring seal on the piston.
- Self lubricating (increased O-Ring life).
- Barrel protection weather cover.
- Stainless steel piston rod.
- Various strokes to suit valve requirements.

PRODUCT SPECIFICATION

- OPERATING TEMPERATURES:** -20°C to 100°C.
- TOP & BOTTOM PLATE:** Carbon Steel or Aluminium, Epoxy Coated.
- BARREL:** Light weight composite tubing, filament wound Fibreglass.
- PISTON:** 304 Stainless Steel.
- PISTON ROD:** 304 Stainless Steel.
- TIE ROD & NUTS:** SAE Grade 5 Stainless Steel threaded rods.
- PRESSURE RATING:** 6 Bar.
- LIP SEAL:** Nitrile.
- GUIDE RING:** PTFE.
- SEAL RINGS:** Neoprene O-Ring seal.
- PROTECTIVE COVER:** 304 Stainless Steel.
- ROD WIPER:** Stainless Steel Housing with Internal Urethane Wiper.
- GLAND BUSHING:** Bronze (SAE 660).
- BELLOWS:** Vinyl.
- PORTS:** At 90° for convenient location.
- LIFTING LUGS:** Steel, coated.

DDAPA

OPTIONS AND ACCESSORIES

- Control valves manual solenoid.
- Proximity limit switches.
- Positioners.
- Position transmitters.
- Manual override system.
- Stainless steel mounting.
- Air fail safe system.
- Positive fail safe spring return.
- Self-contained charging tanks.
- Air boosters.
- Exhaust valves.
- Manual handwheel override.

FAIL SAFE SPRING (OPTIONS)

Single-Acting Actuators consist of either a fail-close spring, which is pre-loaded to provide enough force to close and seal the sleeve upon air loss, or a fail-open spring, which drives the valve open upon air loss.

Fail-open spring Actuators are used primarily in low pressure or partial vacuum services, where the line pressure is not sufficient to fully open the valve.

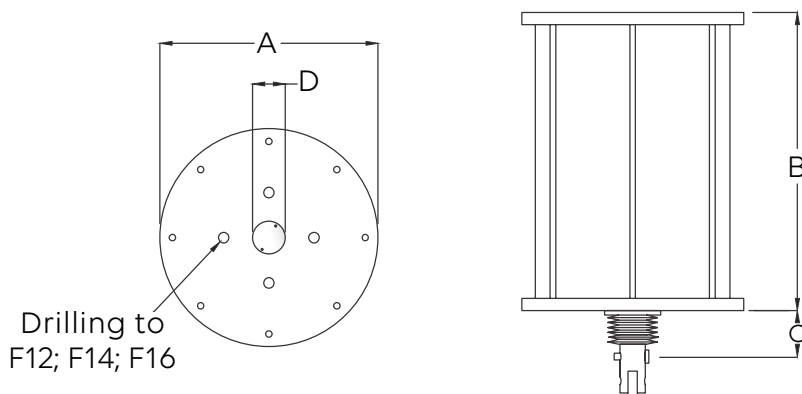

APPLICATIONS

- Mining and mineral processing.
- Power generation.
- Sand and gravel.
- Chemical and soda ash.
- Pulp and paper.
- Environmental and effluent.
- Water and wastewater.



DIMENSIONS AND WEIGHTS

MODEL	BARREL				AIR PORT	WEIGHT (kg)	AIR (litre)
	A	B	C	D			
DA 80	200	183	20	25	1/4"	40	6
DA 100	200	213	20	25	1/4"	60	7
DA 150	200	248	29	25	1/4"	100	15
DA 200	200	353	43	36	1/4"	110	31
DA 250	300	407	43	36	1/4"	120	59
DA 300	350	464	43	36	1/4"	150	70
DA 350	350	623	84	36	1/4"	200	127
DA 400	400	685	84	40	1/2"	250	144
DA 450	450	685	77.5	40	1/2"	390	232
DA 500	500	700	77.5	50	1/2"	500	257
DA 600	550	750	77.5	50	1/2"	550	266

Contact Dual for larger sizes. Dimensions and weights are for guidance only - detailed dimension drawings available on request. All dimensions are in millimeters, unless stated.

CORPORATE HEADQUARTERS: 166 ROTTERDAM ROAD (CNR ROTTERDAM ROAD & ANTWERP STREET) APEX, BENONI, GAUTENG, SOUTH AFRICA
 PO BOX 12520, BENORYN 1540
 TEL: +27 11 422 4326/7
 FAX: +27 11 421 7842
 EMAIL: SALES@DUALVALVES.COM